

## 型号: 17238



- (1) 轴承结构: 含油/双滚珠  
Bearing Construction: oil/double ball
- (2) 外框材质: 铝合金  
Frame material: Aluminum Alloy
- (3) 扇叶材质: PBT加强料  
Fan material: PBT reinforcing material
- (4) 线材: 粗铜线  
Wire: ordinary wire
- (5) 风扇重量: 760g  
Fan weight: 760g



### ★ Dimensions Drawing(外观图)

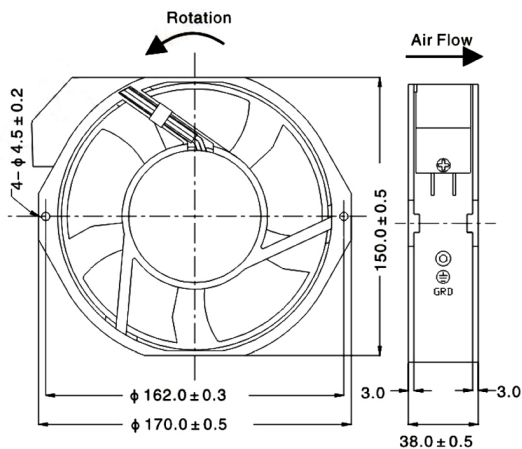

### ★ Characteristic Curves(特性曲线)

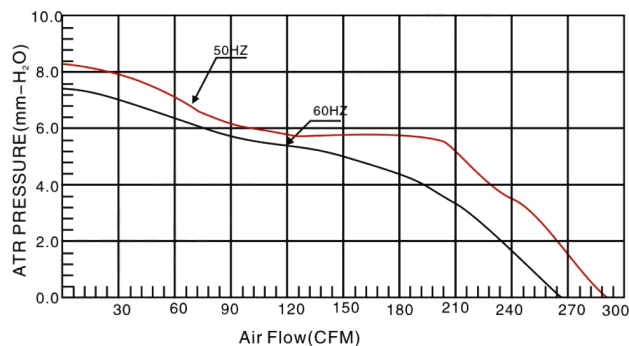

MODEL	Bearing	Rated Voltage	Freq	Current	Input Power	Speed	Air flow		Air Pressure		Niose	Weight
		(V)	(Hz)	(A)	(W)	(RPM)	(CFM)	(m <sup>3</sup> /min)	(mm/H <sup>2</sup> O)	(inch-H <sup>2</sup> O)	(dB-A)	(g)
型号	轴承	电压	频率	电流	功率	转数	气流		风压		噪音	重量
GBOC17238HA1B(S)A	ball	330-380	50/60	0.08	33/30	2500/3000	166/198	4.65/5.54	16.7/19.5	0.66/0.77	57/61	760
GBOC17238HA2B(S)A	ball	220-240		0.17/0.16	33/30	2500/3000	166/198	4.65/5.54	16.7/19.5	0.66/0.77	57/61	
GBOC17238HA2B(S)A	ball	110-120		0.26/0.25	33/30	2500/3000	166/198	4.65/5.54	16.7/19.5	0.66/0.77	57/61	

DC FAN  
DC风扇

AC FAN  
AC风扇

EC FAN  
EC风扇

External Rotor Fan  
外转子风机

Centrifugal Fan  
离心风机

Constant current fan  
恒流风机

Fan Shroud  
风扇网罩