

## 型号: 17251



- (1) 轴承结构: 含油/双滚珠  
Bearing Construction: oil/double ball
- (2) 外框材质: 铝合金  
Frame material: Aluminum alloy
- (3) 扇叶材质: PBT加强料  
Fan material: PBT reinforcing material
- (4) 线材: 优质铜线  
Wire: high quality copper wire
- (5) 风扇重量: 440g  
Fan weight: 440g



### ★ Dimensions Drawing(外观图)

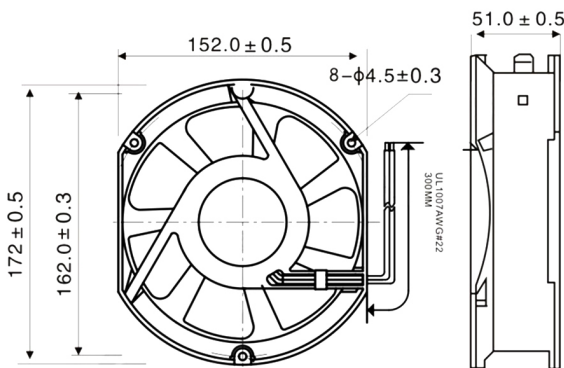

### ★ Characteristic Curves(特性曲线)

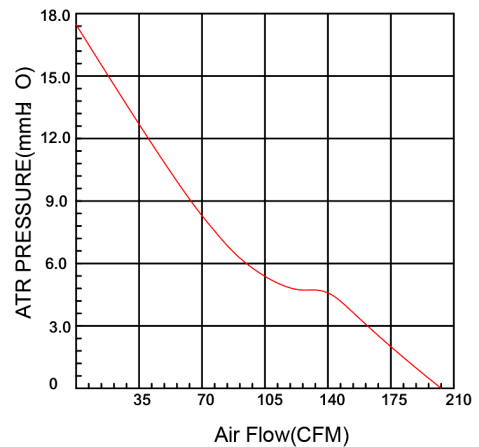

| MODEL            | Bearing System | Rated Voltage (V) | Current (A) | Input Power (W) | Speed (RPM) | Weight (g) |
|------------------|----------------|-------------------|-------------|-----------------|-------------|------------|
| 型号               | 轴承             | 电压                | 电流          | 功率              | 转速          | 重量         |
| GBOC17251M12B(S) | sleeve/ball    | 12                | 1.15        | 14              | 2700        | 440        |
| GBOC17251M24B(S) | sleeve/ball    | 24                | 6           | 15              | 3000        | 440        |

DC FAN  
DC风扇

AC FAN  
AC风扇

EC FAN  
EC风扇

External Rotor Fan  
外转子风机

Centrifugal Fan  
离心风机

Constant current fan  
恒流风机

Fan Shroud  
风扇网罩