

型号：5010



- (1) 轴承结构：含油/双滚珠
Bearing Construction: oil/double ball
- (2) 外框材质：PBT加纤料
Frame material: PBT reinforced material
- (3) 扇叶材质：PBT加纤料
Fan material: PBT reinforcing material
- (4) 线材：优质铜线
Wire: high quality copper wire
- (5) 风扇重量：25g
Fan weight: 25g



★ Dimensions Drawing(外观图)

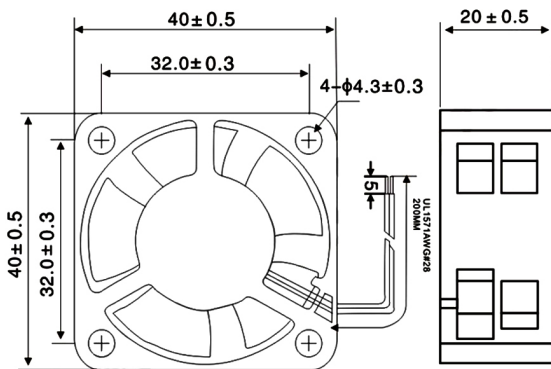

★ Characteristic Curves(特性曲线)

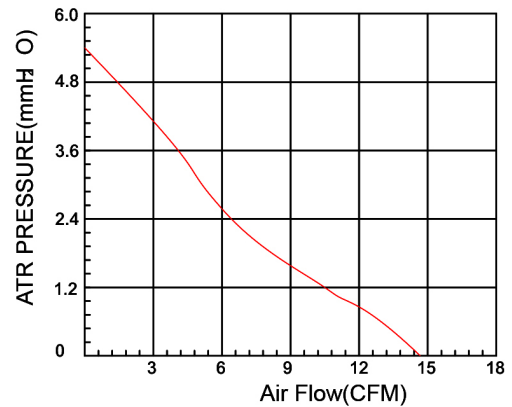

MODEL	Bearing System	Rated Voltage (V)	Current (A)	Input Power (W)	Speed (RPM)	Weight (g)
型号	轴承	电压	电流	功率	转数	重量
GBOC5010M12B(S)	sleeve/ball	12	0.72	0.9	5000	25
GBOC5010M24B(S)	sleeve/ball	24	0.6	1.5	5500	25