

**型号: 7015**



- (1) 轴承结构: 含油/双滚珠  
Bearing Construction: oil/double ball
- (2) 外框材质: PBT加纤料  
Frame material: PBT reinforced material
- (3) 扇叶材质: PBT加纤料  
Fan material: PBT reinforcing material
- (4) 线材: 优质铜线  
Wire: high quality copper wire
- (5) 风扇重量: 58g  
Fan weight: 58g



★ Dimensions Drawing(外观图)

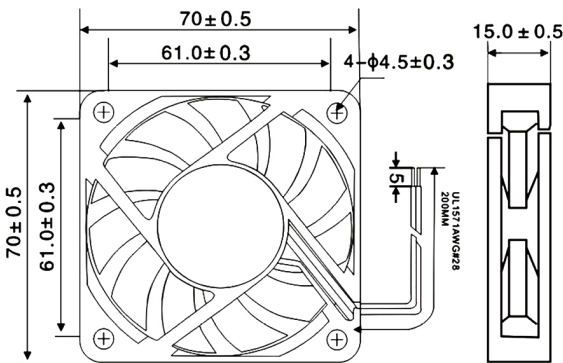

★ Characteristic Curves(特性曲线)

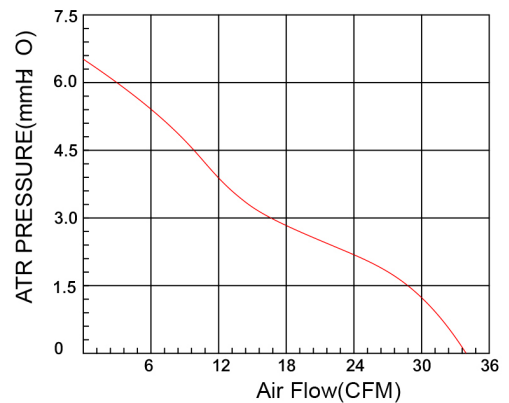

MODEL	Bearing System	Rated Voltage (V)	Current (A)	Input Power (W)	Speed (RPM)	Weight (g)
型号	轴承	电压	电流	功率	转速	重量
GBOC7015M12B(S)	sleeve/ball	12	1.75	2.1	4600	58