



(1) 品名：百叶窗

Name: Blinds

(2) 外壳材质：再生料/原料

Shell material: recycled material/raw material

(3) 工艺：普通/密封圈

Process: normal/sealing ring

(3) 工作环境：-10°C~±55°C

Working environment: -10°C ~ ± 55°C

(4) 防护等级：IP44

Containment level: IP44

(5) 防尘率：90%

Dustproof rate: 90%



Dimensions Drawing(外观图)

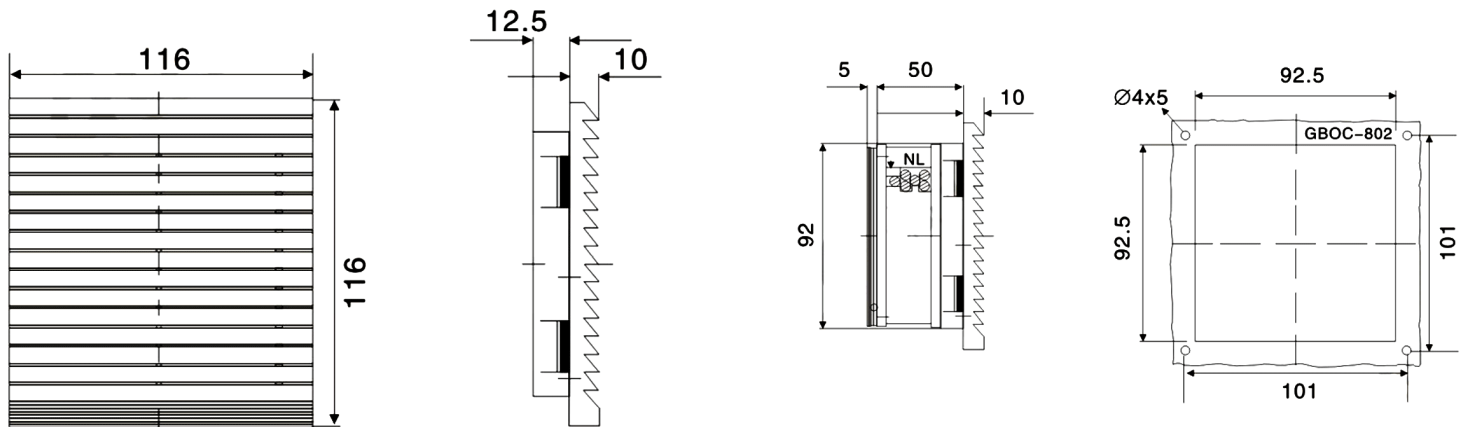

DC FAN  
DC风扇

AC FAN  
AC风扇

EC FAN  
EC风扇

External Rotor Fan  
外转子风机

Centrifugal Fan  
离心风机

Constant current fan  
恒流风机

Fan Shroud  
风扇网罩