

型号: 12038



- (1) 轴承结构: 含油/双滚珠
Bearing Construction: oil/double ball
- (2) 外框材质: 铝合金
Frame material: Aluminum Alloy
- (3) 扇叶材质: PBT加强料
Fan material: PBT reinforcing material
- (4) 线材: 铜包铝
Wire: ordinary wire
- (5) 风扇重量: 340g
Fan weight: 340g



★ Dimensions Drawing(外观图)

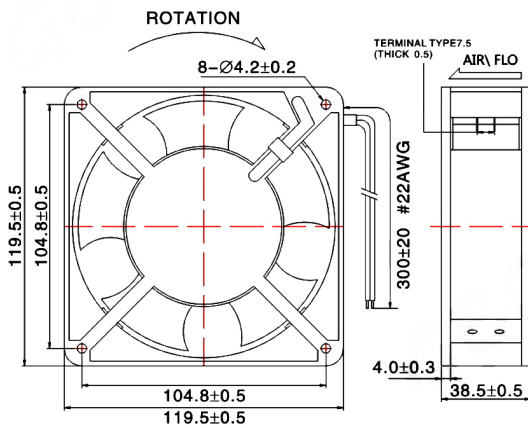

★ Characteristic Curves(特性曲线)

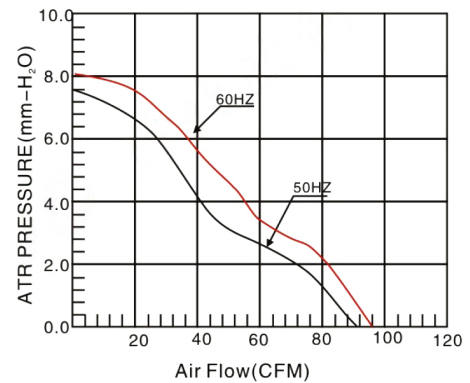

MODEL	Bearing System	Rated Voltage (V)	Freq (Hz)	Current (A)	Input Power (W)	Speed (RPM)	Air flow (CFM)	Static Pressure (mm-H ₂ O)	Niose Level (dB-A)	Weight (g)
型号	轴承	电压	频率	电流	功率	转速	气流	风压	噪音	重量
gboc12038HA2SA	Sleeve	220	50/60	0.12	18	2200	80	7.36	40	340
gboc12038HA2BA	Ball	220	50/60	0.12	18	2200	80	7.40	40	340

DC FAN
DC风扇

AC FAN
AC风扇

EC FAN
EC风扇

External Rotor Fan
外转子风机

Centrifugal Fan
离心风机

Constant current fan
恒流风机

Fan Shroud
风扇网罩